

PolyBronze™ Spring Plate Bearings - Installation Instructions

Part Number 2231800

Protected by US Patent 7,325,796

Cars applicable:

'78.5 – '95 944/924/924S/951/968

Parts list:

Qty	Description
4	Bronze Bearing
4	Bearing Race
8	2mm Spacers
4	M6x.75 Grease fittings

Introduction –

PolyBronze Spring Plate Bearings replace factory rubber spring plate bushings. The bearings provide precise suspension movement without deformation under heavy corner loads. They are very low friction and will not squeak.

PolyBronze Spring Plate Bearings are provided with grease fittings making re-lubrication easy.

Note – PolyBronze Spring Plate Bearings should be lubricated at 3,000 mile intervals or annually. Race cars should lubricate more frequently. Use quality grease rated for extreme pressure.

Required but not included:

JB Weld brand 2 part steel epoxy (or equivalent)
Adhesive caulk (usually not required)

Step by Step Instructions

1 – Remove rubber bushings from spring plates.

With spring plates removed from car, secure spring plate in a bench vise.

Use a propane torch to heat the inside of the spring plate tube until a small amount of rubber smoke is visible. The heat will allow the rubber to pull away from the metal easily.

Use a flat blade screwdriver to separate the rubber bushings from the spring plate. Pry the bushings off.

Use a razor knife to remove any remaining large bits of rubber.

Use sandpaper or a chemical paint stripper to remove the last bit of remaining rubber. The spring plate tube must be completely clean of rubber, dirt and grease.



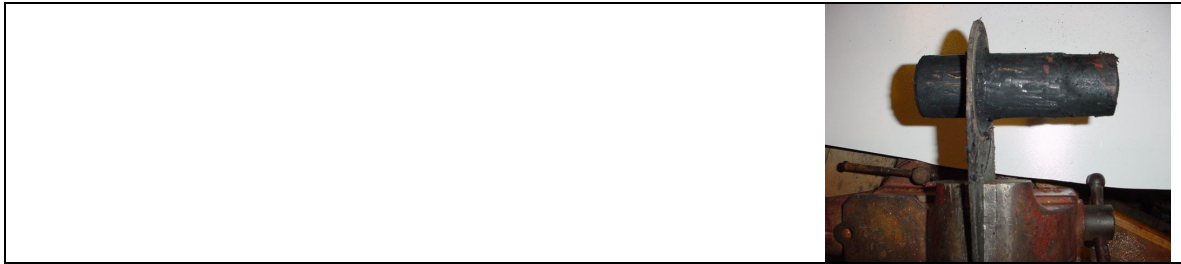

2 – De-burr spring plate tube.

Smooth any surface irregularities or ridges on the spring plate tube using a file or fine sandpaper.

Inspect the spring plate fillet welds looking for high points and weld spatter. Trial fit the bearing race to ensure the fillet weld does not prevent the race from seating fully on the spring plate. If required, file down any high points on the fillet weld.

This is an excellent opportunity to have your spring plates re-plated.

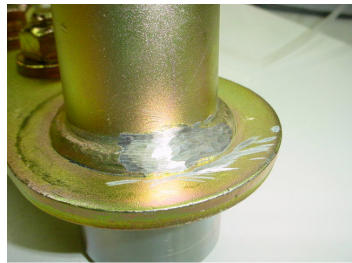

3 – Fit bearing races onto spring plates.

To accommodate for manufacturing variation in spring plate shaft, races are made slightly oversize. Races are glued to the spring plate and the gap filled using JB Weld (JB Weld is a two-part metal epoxy, not included).

Coat the inside of the race with a thin layer of JB weld. Similarly apply a thin coat to the entire mating surface of the spring plate. Your goal is smooth thin layer on both mating surfaces that will completely fill the space between race and control arm with no voids.

Press race on with a twisting motion until race butts against the spring plate flat section.

VERY IMPORTANT – Be sure to clean ALL adhesive off the race. Even a tiny amount will interfere with the bearing fit.

Allow the JB Weld to cure.

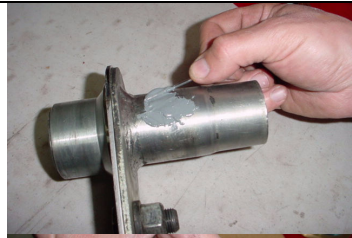

4 - Install bearings into the spring plate cover plates.

Clean any dirt, grease and rubber residue out of the inside of the cover plate. Use a flat file to remove any high points on face of the cover plate providing a flat surface to meet the bearing flange.

BE SURE TO WET THE POLYURETHANE with a soap and water solution to lubricate and ease installation. Press the bearing into the cover plate. The press fit should require about 75-150 lbs. Tip – get the bearing started, then use a bench vise to press until the bearing flange is flush against the mount.

If the bearing is loose in the cover plate, the fit can be assisted using urethane-based adhesive caulk. Apply a layer between the red polyurethane surface and the spring plate cover.

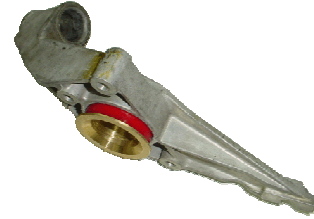

5 – Install spring plate cover grease fittings

Spring plate covers are drilled and tapped. Provided grease fittings are threaded into place.

With the bearing fully installed, drill a 1/16 inch through-hole through the spring plate cover and the bearing as shown. The hole should intersect the circumferential grease groove in the bearing. Drill the hole 5/8 inch from the bearing flange to intersect the groove.

Drill and tap the hole for M6x.75 threads to a depth of 3/8 inch.

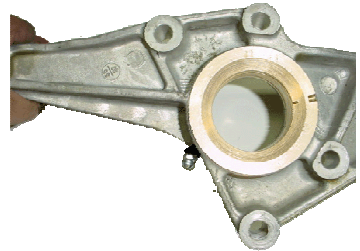

6 – Install bearings into the torsion bar tube.

Clean any dirt and grease out of the inside of the torsion bar tube. Rubber residue from the old bushing can be removed by scraping and using sandpaper.

BE SURE TO WET THE POLYURETHANE with a soap and water solution to lubricate and ease installation. Press the bearing into the torsion bar tube. Tip – get the bearing started, then use



the cover plate and bolts to press the bearing into place. Use a piece of wood between cover plate and bearing.

If the bearing is loose in the torsion tube, the fit can be assisted using urethane-based adhesive caulk. Apply a layer between the red polyurethane surface and the torsion tube.



7 – Install torsion bar tube grease fittings

Torsion bar tube is drilled and tapped. Provided grease fittings are threaded into place.

With the bearing fully installed, drill a 1/16 inch through-hole through the torsion bar tube and the bearing as shown. Drill the front side of the torsion tube. The hole should intersect the circumferential grease groove in the bearing. Drill the hole 5/8 inch from the bearing flange to intersect the groove.

Drill and tap the hole for M6x.75 threads to a depth of 3/8 inch.

Thread in the grease fitting into place, orienting the fitting such that it points downward.



8 – Test fit spring plates into car without torsion bars.

Lubricate PolyBronze bearing surfaces with quality grease. Install cover plate using 4 x 2mm spacers (provided) and tighten cover plate bolts. Check that spring plate moves freely without binding.

In the event spring plate does not move freely it may be necessary to stack additional washers under the spring plate cover to gain additional clearance.

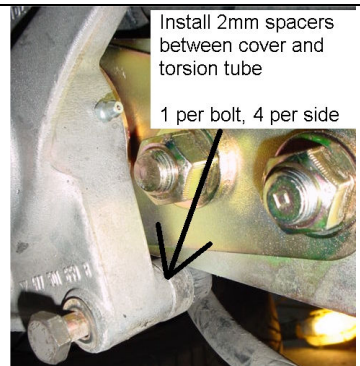

9 – Install spring plates with torsion bars.

Using the same spacers determined in step 6, install spring plates with torsion bars.

10 – Lubricate PolyBronze spring plate bearings.

Using a grease gun loaded with quality grease rated for extreme pressure, inject grease into each nipple. Inject enough grease so that a bit squeezes out of each bearing.

Re-lubricate annually or every 3,000 miles. Race cars should lubricate more frequently.

