



991 Control Arm Lower Sealed Monoball Kit - Installation Instructions

Part #2260009

Cars applicable:

991

Parts list:

Qty	Description
4	Lower control arm, weather sealed monoball cartridges
1	Loctite 680 retaining compound 5ml capsule

Tools Required:

arbor press or hydraulic press, solvent (aerosol brake cleaner or similar)

Introduction –

Congratulations on your selection of the Elephant Racing 991 Rear Control Arm Lower Sealed Monoball Kit. These cartridges replace compliant factory rubber bushings with hardened-steel spherical bearings. Unlike poly bushings that bind and resist movement, true spherical bearings allow free motion on multiple axes.

Our fully sealed monoball cartridge kits feature maintenance free PTFE linings requiring no supplemental lubrication. We've designed in weather seals to keep dirt out and extend product life. This is the only monoball suitable for street or extended track use. Dirt and water contaminate ordinary products and accelerate wear.



Rear Control Arm Lower Sealed Monoball Kit

Monoball cartridge installed in original arm

Step-by-Step Installation -

1 – Remove rear lower control arms from the car.

Refer to an appropriate shop manual



2 –Remove rubber bushing

Use a press to press the bushing out. Focus the force on the outer bushing sleeve.

Thoroughly clean the bushing bore with solvent, removing all oil/grease and dirt in preparation for the Loctite 680 Retaining Compound.

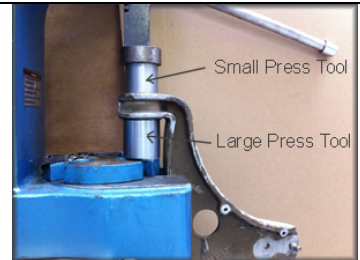

3 – Install monoball cartridges into arms

Apply a thin film of the Loctite 680 to the entire outer diameter of the monoball cartridge and inner bore of the arm. Insert the cartridge into the beveled side of the arm as shown. Press into place until the flange is fully seated.

Note, do not press on the center bearing spacer. Doing so might damage the bearing. Instead, press only on the surface of the monoball housing.

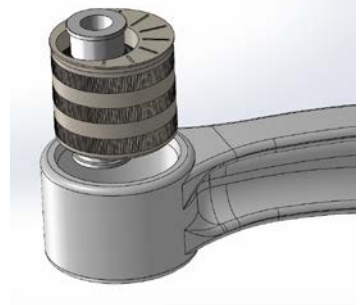

4 – Install arms into car.